

Wireless 0-10 Volt Meter Sensor

General Description

The Senseit Wireless Voltage Meter measures the voltage between two electrical points. It can be connected to the power and ground of any voltage source and measure within stated accuracy up to 10 VDC. It can be connected to any kind of variable voltage device, such as a transducer or sensor that outputs voltage. If the device to be measured is passive, the user must supply their own excitation voltage to the device.

- Accurate to $\pm 3.0\%$ full scale (FS) of voltage range.
- Accurate to $\pm 0.5\%$ FS with user calibration.
- Interfaces with any variable voltage device.
- 5 mV Resolution.



Free iSenseit basic online wireless sensor monitoring and notification system to configure sensors, view data and set alerts via SMS text and email.

Principle of Operation

Senseit Wireless Voltage Meters read the voltage difference between two electrical points and reports back the measured voltage. It is programmed to sleep for a user-given time interval (heartbeat) and then wake up, convert the analog data, mathematically compute the voltage, and transmit the data to the gateway, where it is then logged into a cloud service. The user can configure defined thresholds and have the system alert on threshold breaches.

Example Interacing

- Battery Health
- Voltage Measurement
- Transducer Measurement
- Machinery
- Electrical Motors
- And many more...

Senseit Sensor Core Specifications

- Wireless Range: 250 - 300 ft. (non line-of-sight / indoors / through walls, ceilings & floors) *
- Communication: RF 900 MHz
- Power: Replaceable batteries (optimized for long battery life) - Line-power (AA version) options available
- Battery Life (at 1 hour heartbeat setting) **
AA battery > 4-8 years

* Actual range may vary depending on environment.

** Battery life is determined by sensor reporting frequency and other variables.

Wireless 0-10 Volt Meter Sensor (AA)

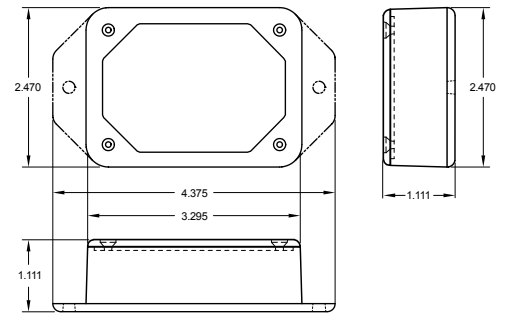

| Technical Specifications | |
|---|---|
| Supply Voltage | 2.0 - 3.6 VDC * (3.0 - 3.6 VDC Using Power Supply) |
| Current Consumption | 0.7 μ A (sleep mode) 2 mA (radio idle/off mode) 2 mA (measurement mode) 25 mA (radio RX mode) 35 mA (radio TX mode) |
| Operating Temperature Range (Board Circuitry and Batteries) | -18°C to 55°C (0°F to 130°F) using alkaline -40°C to 85°C (-40°F to 185°F) using lithium ** |
| Optimal Battery Temperature Range (AA) | +10°C to +50°C (+50°F to +122°F) |
| Voltage Range | 0 – 10 Volts DC*** |
| Resolution | ~5 mV |
| Accuracy | +/- 3% FS |
| User Calibrated Accuracy | +/- .5% FS **** |
| Open Circuit Voltage | ~0.000 Volts |
| Max Rated Input | 20 Volts |
| Leaded Wire Specification | 2 Wires, 1 ft. (12 in.), Red (+), Black (-), 18 AWG (Custom lengths available upon request) |
| Weight | 4.0 oz. |
| Wireless Range | 250 - 300 ft. (Indoors /Through walls, ceilings & floors) Range may vary according to environmental variables |
| Certifications | 900 MHz product; FCC ID: ZTL- RFSC1 and IC: 9794A-RFSC1. |



- * Hardware cannot withstand negative voltage. Please take care when connecting a power device.
- ** At temperatures above 100°C, it is possible for the board circuitry to lose programmed memory.
- *** The sensor is capable of measuring above 10 volts but may not meet the specified accuracy above this value.
- **** For best results calibrate at a voltage between 50% and 90% of the voltage range.

Proper Installation

If the sensor is not connected to the power source properly, it will appear that the sensor is broken. Please follow this wiring diagram to ensure proper performance and detection.

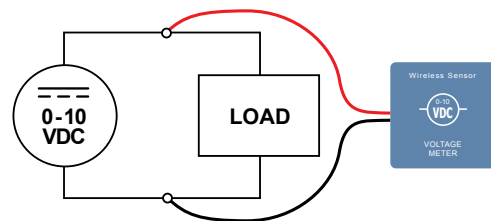

Power Options

Two replaceable 1.5V AA sized batteries are included with the standard model. A line-power version with battery backup is also available - allowing it to be powered by a standard 3.0 - 3.6V power supply and use the internal batteries if there is a power interruption.

Power options must be selected at time of purchase as the internal hardware of the sensor must be changed to support the selected power requirements.